



***MATRIX***



**THE SOLUTION TO EQUIP EVERY VAN**



## EASY TO DESIGN

WITH THE CONFIGURATOR YOU CAN EQUIP YOUR VAN AS YOU WANT!

1

### IT WORKS ONLINE

No installation required; compatible with the most popular browsers

2

### SIMPLE AND INTUITIVE

Place the modules inside your van

3

### PROJECT IN A CLICK

Save your project and export it to PDF or Excel to get a quote from your Reseller



## YOUR LAY-OUT STEP BY STEP



### 1 PROJECT YOUR LAY-OUT

With the online planner you can design the lay-out that best fits to your needs



### 2 EXPORT YOUR PROJECT

Save the project in Excel, Pdf or .mtx format



### 3 CONTACT FACOM RESELLER

For your order, please contact your FACOM dealer



### 4 WATCH THE ASSEMBLING INSTRUCTIONS

On FACOM YouTube channel you can find the video tutorials that show you how to do it.

## EASY TO COMPOSE

ALL THE ELEMENTS OF MATRIX RANGE ARE MULTIPLES OF THESE MODULES:

**MATRIX is modularity** makes it possible to combine wheel-bases, drawer chests and shelves with simple and visible rules. That's why **MATRIX** easily fits to all needs and vans.

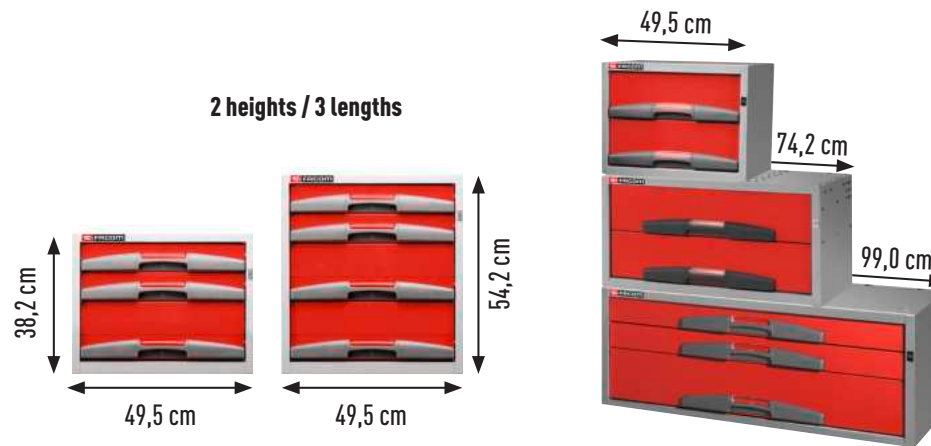

- 1 Every lay-out starts with the **WHEEL-BASES** available in 7 models, suitable for all types of vans.
- 2 The **MODULES** are the heart of Matrix: available in 17 variants designed with different sizes and combinations of drawers.
- 3 **SHELVES** are to be placed on top of bases or drawer chests and have 3 different depths to best follow the van's shape.
- 4 A wide range of **ACCESSORIES** allows to complete the lay-out.

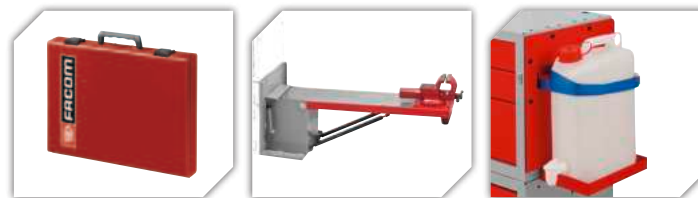

## EASY TO ASSEMBLE

WITH THE FIXING SYSTEM

Save the assembling costs. You can mount it yourself!

- 5 Steel fixing bar
- 6 U-brackets and hardware for fixing included

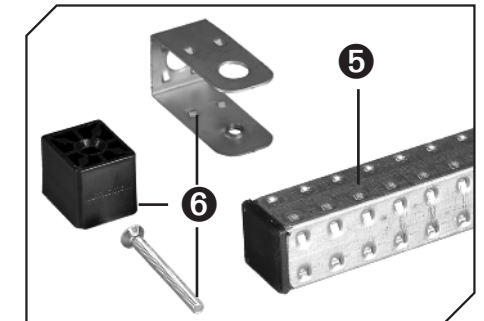

Scan the QR code or go on FACOM YouTube channel to discover more

## SMART SOLUTION

**MATRIX is the system that allows you to have all your tools perfectly organized when you're on the move and to locate them instantly for use once you reach the job.**

A combination of removable tool boxes and fixed drawers can be fitted to suit a whole range of needs.

The project combines know-how and takes into account the priorities of technicians and craftsmen: MATRIX is a truly modular solution that can be adapted and combined to offer specific solutions to meet every professional requirement.



### MATRIX IS TRULY AN INGENIOUS SYSTEM

- Work is simpler and less strenuous.
- The outfitted vehicle becomes one big workshop, with everything within easy reach.
- Just open the tool boxes and pick what you need.
- A practical, ergonomic handle that allows you to open the drawers even with just one hand.

Time saving, energy saving, improved working efficiency. In other words: everything on board!



### REMOVAL BOXES

An excellent slide system assures the total opening of the drawer (max. load 20 Kg).



### TAKE EVERYTHING WITH YOU

Ready to follow you anywhere: the tool boxes can be removed with the greatest of ease, without the need to remove any other parts.



### ERGONOMIC HANDLES:

drawers can be opened with one hand.



### EASY OPENING

without removing the tool box, simply flip open the clip.



## COMPOSITION

Dimensions: L. 990 x D. 375 x H. 1306 mm  
Weight: 76 Kg

Code	Description	Pc.
F50000023	DRAWER CHEST WITH TOOL BOX	1
F50000062	DRAWER CHEST	1
F50020009	WHEEL-BASE	1
U50020066	ROLL-HOLDER	1
F50020048	FIXING BAR	1
F50030078	SHELF WITH TRAY-HOLDER	1
F50030049	UPRIGHTS 375 MM - SERIE 5003 ME	1



## COMPOSITION

Dimensions: L. 990 x D. 375 x H. 1014 mm  
Weight: 74 Kg

Code	Description	Pc.
F50000024	DRAWER CHEST WITH TOOL BOX	1
F50000063	DRAWER CHEST	1
F50020012	WHEEL-BASE	1
F50020031	LARGE SHELF	1
F50020066	ROLL-HOLDER	1



Most common compatible vehicles:

Make	Vehicule
CITROËN	JUMPY Wheel-base 3122 roof 1750
	JUMPER Wheel-base 3000 roof 1662 and Wheel-base 3450 roof 1662 and 1932
FIAT	SCUDO Wheel-base 3122 roof 1750
	DUCATO Wheel-base 3000 roof 1662 and Wheel-base 3450 roof 1662 and 1932
	TALENTO Wheel-base 3098 roof 1387 and 1898
FORD	TRANSIT Wheel-base 2933 roof 1430 and 1745 traction avant
	TRANSIT Wheel-base 3300 roof 1745 and 1985 traction avant
	CUSTOM Wheel-base 2933 roof 1778 and Wheel-base 3300 roof 1778
IVECO	DAILY Wheel-base 3000 roues singles roof 1545 and 1900
	DAILY Wheel-base 3300 roues singles roof 1900 and 2100
MERCEDES	SPRINTER Wheel-base 3000 roof 1633 and 1855 and Wheel-base 3550 roof 1633 and 1855
	VITO Long Wheel-base 3200 roof 1760
NISSAN	NV300 Wheel-base 3098 roof 1898 and Wheel-base 3498 roof 1898
	NV400 Wheel-base 3182 roof 1700 and 1894
OPEL	MOVANO Wheel-base 3078 roof 1670 and 1912 and Wheel-base 3578 roof 1912 and 2146 and Wheel-base 4078 roof 1912 and 2146
	VIVARO Wheel-base 3098 roof 1913 and Wheel-base 3498 roof 1913
PEUGEOT	EXPERT Wheel-base 3450 roof 1662
	BOXER Wheel-base 3000 roof 1662 and Wheel-base 3450 roof 1662 and Wheel-base 3450 roof 1932
RENAULT	TRAFIC Wheel-base 3098 roof 1913 and Wheel-base 3498 roof 1913
	MASTER Wheel-base 3182 roof 1700 and 1894 and Wheel-base 3682 roof 1894 and 2144 and Wheel-base 4332 roof 1894 and 2144
VOLKSWAGEN	T5 Wheel-base 3000 roof 1626 and Wheel-base 3400 roof 1626 and 1940

Most common compatible vehicles:

Make	Vehicule
CITROËN	BERLINGO Wheel-base 2693 roof 1250
	NEMO Wheel-base 2513 roof 1181
FIAT	FIORINO Wheel-base 2513 roof 1205
PEUGEOT	RANCH Wheel-base 2693 roof 1250
RENAULT	KANGO Wheel-base 2600 roof 1257
	KANGO LONG Wheel-base 2600 roof 1257
	KANGO 2010 Wheel-base 2697 roof 1251
	KANGO 2010 Wheel-base 3081 roof 1190
VOLKSWAGEN	CADDY Wheel-base 2682 - 3002 roof 1257



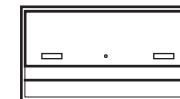

## BASE

Open model for wheel-side  
Up-and-over door with security locking  
Inside available height 480 mm  
Dimensions: L. 495 x D. 375 x H. 542 mm  
Weight: 13 Kg

**F50020008**



## BASE

Open model for SHAPED wheel-side  
Up-and-over door and security locking  
Inside available height 325 mm  
Dimensions: L. 990 x D. 375 x H. 382 mm  
Weight: 15 Kg

**F50020012**



## BASE

Open model for wheel-side  
Up-and-over door with security locking  
Inside available height 480 mm  
Dimensions: L. 990 x D. 375 x H. 542 mm  
Weight: 16 Kg

**F50020009**

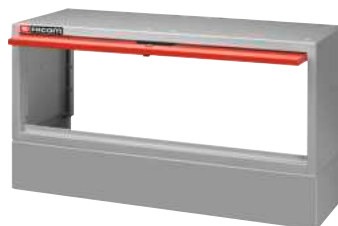

## BASE

Open model for wheel-side  
Up-and-over door with security locking  
Inside available height 325 mm  
Dimensions: L. 990 x D. 375 x H. 382 mm  
Weight: 15,2 Kg

**F50020004**



## BASE

Open model for wheel-side  
Up-and-over door with security locking  
Inside available height 480 mm  
Dimensions: L. 1237,5 x D. 375 x H. 542 mm  
Weight: 17,5 Kg

**F50020010**

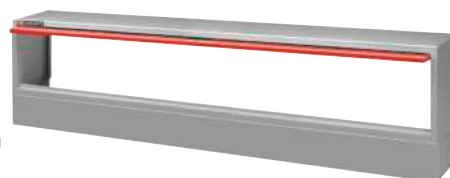

## BASE

Open model for wheel-side  
Up-and-over door with security locking  
Inside available height 325 mm  
Dimensions: L. 1237,5 x D. 375 x H. 382 mm  
Weight: 16 Kg

**F50020005**



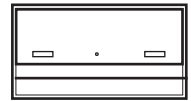

## BASE

Closed model  
Up-and-over door and security locking  
Inside available height 325 mm  
Dimensions L. 495 x D. 375 x H. 382 mm  
Weight: 8,3 Kg

**F50020019**



## CASE HOLDER BASE

Belt-type case holder  
Belt in syntetic anti-graze material  
Inside available dimensions: L. 920 x D. 340 x H. 510 mm  
Dimensions: L. 990 x D. 375 x H. 542 mm  
Weight: 12,5 Kg

**F50020024**

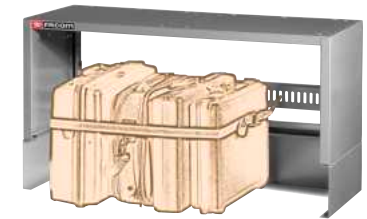

## BASE

Closed model  
Up-and-over door and security locking  
Inside available height 325 mm  
Dimensions: L. 990 x D. 375 x H. 382 mm  
Weight: 15 Kg

**F50020020**



## CASE BAR FOR CASE HOLDER BASE F50020024

Can be used also with uprights 5003 MD-ME-MF  
Steel casing  
Dimensions: L. 930 x D. 30 x H. 130 mm  
Weight: 1,8 Kg

**U500200350**



## BASE

Open model for wheel-side and vice assembly  
To be used in combination with worktop  
with vice F50020076  
Inside available height 500 mm  
Dimensions: L. 990 x D. 375 x H. 502 mm  
Weight: 12,5 Kg

**U50020070**



## BELT FOR CASE HOLDER BASE F50020024

Spare belt in syntetic anti-graze material  
Blocking clamp and hooks in steel  
Length: max. 2130 mm  
Weight: 0,4 Kg

**⚠ Warning: not suitable for lifting**

**U500200360**



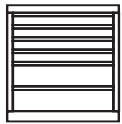

## DRAWER CHEST WITH REMOVABLE BOXES

Drawer chest with 2 boxes F50000301 and 2 boxes F50000302  
 Supplied with fixing bracket U50020047  
 Dimensions: L.495 x D. 375 x H. 542 mm  
 Weight: 29 Kg

**F50000023**



## DRAWER CHEST WITH REMOVABLE BOXES

Drawer chest with 4 boxes F50000301 and 1 box F50000302  
 Supplied with fixing bracket U50020047  
 Dimensions: L. 495 x D. 375 x H. 542 mm  
 Weight: 30 Kg

**F50000024**



## DRAWER CHEST WITH REMOVABLE BOXES

Drawer chest with 2 boxes F50000302  
 Supplied with fixing bracket U50020047  
 Dimensions: L. 495 x D. 375 x H. 382 mm  
 Weight: 17 Kg

**F50000001**



## DRAWER CHEST WITH REMOVABLE BOXES

Drawer chest with 4 boxes F50000301  
 Supplied with fixing bracket U50020047  
 Dimensions: L. 495 x D. 375 x H. 382 mm  
 Weight: 25 Kg

**F50000003**



## DRAWER CHEST WITH REMOVABLE BOXES

Drawer chest with 2 boxes F50000301 and 2 drawers H 75 mm  
 Supplied with fixing bracket U50020047  
 Dimensions : L.495 x D. 375 x H. 382 mm  
 Weight: 21,5 Kg

**F50000101**





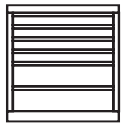

## DRAWER CHEST

Drawer chest with 2 drawers H 155 mm  
Supplied with fixing bracket U50020047  
Dimensions: L. 495 x D. 375 x H. 382 mm  
Weight: 13 Kg

F50000041



## DRAWER CHEST

Drawer chest with 3 drawers H 155 mm  
Supplied with fixing bracket U50020047  
Dimensions: L. 495 x D. 375 x H. 542 mm  
Weight: 19 Kg

F50000062



## DRAWER CHEST

Drawer chest with 2 drawers H 75 mm and 1 drawer H 155 mm  
Supplied with fixing bracket U50020047  
Dimensions: L. 495 x D. 375 x H. 382 mm  
Weight: 16 Kg

F50000042



## DRAWER CHEST

Drawer chest with 2 drawers H 75 mm and 2 drawers H 155 mm  
Supplied with fixing bracket U50020047  
Dimensions: L. 495 x D. 375 x H. 542 mm  
Weight: 21 Kg

F50000063



## DRAWER CHEST

Drawer chest with 4 drawers H 75 mm  
Supplied with fixing bracket U50020047  
Dimensions: L. 495 x D. 375 x H. 382 mm  
Weight: 15 Kg

F50000043



## DRAWER CHEST

Drawer chest with 4 drawers H 75 mm and 1 drawer H 155 mm  
Supplied with fixing bracket U50020047  
Dimensions: L. 495 x D. 375 x H. 542 mm  
Weight: 23 Kg

F50000064





## DRAWER CHEST

Drawer chest with 6 drawers H 75 mm  
Supplied with fixing bracket U50020047  
Dimensions: L. 495 x D. 375 x H. 542 mm  
Weight: 24 Kg

F50000065



## DRAWER CHEST

Drawer chest with 2 drawers H 75 mm  
and 2 drawers H 155 mm  
Supplied with fixing bracket U50020047  
Dimensions: L. 742,5 x D. 375 x H. 542 mm  
Weight: 30 Kg

F50000072



## DRAWER CHEST

Drawer chest with 2 drawers H 155 mm  
Supplied with fixing bracket U50020047  
Dimensions: L. 742,5 x D. 375 x H. 382 mm  
Weight: 22 Kg

F50000051



## DRAWER CHEST WITH LONG DRAWERS

Drawer chest with 2 drawers H 155 mm  
Supplied with fixing bracket U50020047  
Dimensions: L. 990 x D. 375 x H. 382 mm  
Weight: 28 Kg

F50000084



## DRAWER CHEST

Drawer chest with 2 drawers H 75 mm  
and 1 drawer H 155 mm  
Supplied with fixing bracket U50020047  
Dimensions: L. 742,5 x D. 375 x H. 382 mm  
Weight: 26,5 Kg

F50000052



## DRAWER CHEST WITH LONG DRAWERS

Drawer chest with 2 drawers H 75 mm  
and 1 drawer H 155 mm  
Supplied with fixing bracket U50020047  
Dimensions: L. 990 x D. 375 x H. 382 mm  
Weight: 30 Kg

F50000085



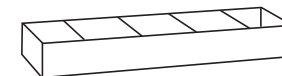

## SHELF

Model for modules 495 mm with 2 removable dividers  
Dimensions: L. 495 x D. 375 x H. 90 mm - Weight: 4 Kg

F50020030



## SHELF

Model for modules 742 mm  
with 4 removable dividers  
Dimensions: L. 742,5 x D. 375 x H. 90 mm - Weight: 5 Kg

F50020033



## SHELF

Model for modules 990 mm  
with 4 removable dividers  
Dimensions: L. 990 x D. 375 x H. 90 mm - Weight: 8 Kg

F50020031



## SHELF

Model for modules 1237,5 mm with 6 removable dividers  
Dimensions: L. 1485 x D. 375 x H. 90 mm - Weight: 11 Kg

F50020032



## EXTENSIBLE SHELF

Extensible shelf for pipe storing  
Dimensions: L. 1650/3100 x D. 300 x H. 90 mm - Weight: 20 Kg

F50020035



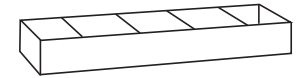

DEPTH: 200 MM

## SHELF

Shelf with 4 removable dividers  
To combine with the uprights of serie 5003 MD  
Dimensions: L. 682,5 x D. 200 x H. 90 mm - Weight: 3 Kg

U50030028



## SHELF

Shelf with 4 removable dividers  
To combine with the uprights of serie 5003 MD  
Dimensions: L. 930 x D. 200 x H. 90 mm - Weight: 5.1 Kg

U50030024



## SHELF

Shelf with 5 removable dividers  
To combine with the uprights of serie 5003 MD  
Dimensions: L. 1177,5 x D. 200 x H. 90 mm - Weight: 6,5 Kg

U50030029



## SHELF

Shelf with 6 removable dividers  
To combine with the uprights of serie 5003 MD  
Dimensions: L. 1425 x D. 200 x H. 90 mm - Weight: 7,4 Kg

U50030025



DEPTH: 275 MM

## SHELF

Shelf with 4 removable dividers  
To combine with the uprights of serie 5003 MF  
Dimensions: L. 682,5 x D. 275 x H. 90 mm - Weight: 5 Kg

U50030090



## SHELF

Shelf with 4 removable dividers  
To combine with the uprights of serie 5003 MF  
Dimensions: L. 930 x D. 275 x H. 90 mm - Weight: 6 Kg

F50030026



## SHELF

Shelf with 5 removable dividers  
To combine with the uprights of serie 5003 MF  
Dimensions: L. 1177,5 x D. 275 x H. 90 mm - Weight: 6,5 Kg

U50030091



## SHELF

Shelf with 6 removable dividers  
To combine with the uprights of serie 5003 MF  
Dimensions: L. 1425 x D. 275 x H. 90 mm - Weight: 7 Kg

U50030027



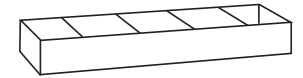

DEPTH: 375 MM

## SHELF

Shelf with 4 removable dividers  
To combine with the uprights of serie 5003 ME  
Dimensions: L. 682,5 x D. 375 x H. 90 mm - Weight: 5,5 Kg

**U50030030**



## SHELF

Shelf with 4 removable dividers  
To combine with the uprights of serie 5003 ME  
Dimensions: L. 930 x D. 375 x H. 90 mm - Weight: 5 Kg

**F50030031**



## SHELF

Shelf with 5 removable dividers  
To combine with the uprights of serie 5003 ME  
Dimensions: L. 1177,5 x D. 375 x H. 90 mm - Weight: 7 Kg

**F50030033**



## SHELF

Shelf with 6 removable dividers  
To combine with the uprights of serie 5003 ME  
Dimensions: L. 1425 x D. 375 x H. 90 mm - Weight: 10,5 Kg

**F50030032**



## SHELF WITHOUT DIVIDERS

To combine with the uprights of serie 5003 MD  
Dimensions: L. 187,5 x D. 200 x H. 90 mm - Weight: 1 Kg

**U50030085**

Supplied with antislip rubber mat



## SHELF WITHOUT DIVIDERS

To combine with the uprights of serie 5003 MF  
Dimensions: L. 187,5 x D. 275 x H. 90 mm - Weight: 1,3 Kg

**U50030086**

Supplied with antislip rubber mat



## SHELF WITHOUT DIVIDERS

To combine with the uprights of serie 5003 ME  
Dimensions: L. 187,5 x D. 375 x H. 90 mm - Weight: 1,6 Kg

**U50030087**

Supplied with antislip rubber mat





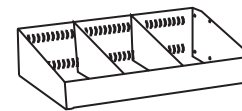

DEPTH: 275 MM

## INCLINED SHELF

Inclined shelf with 2 removable dividers  
To combine with the uprights of serie 5003 MF  
Dimensions: L. 435 x D. 275 x H. 185 mm - Weight: 3 Kg

U50030036



## INCLINED SHELF

Inclined shelf with 4 removable dividers  
To combine with the uprights of serie 5003 MF  
Dimensions: L. 682,5 x D. 275 x H. 185 mm - Weight: 4,5 Kg

U50030039

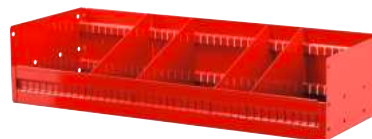

## INCLINED SHELF

Inclined shelf with 4 removable dividers  
To combine with the uprights of serie 5003 MF  
Dimensions: L. 930 x D. 275 x H. 185 mm - Weight: 6,5 Kg

F50030037

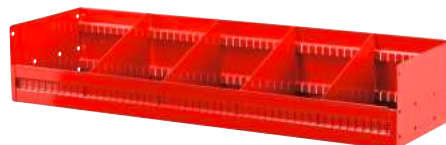

## INCLINED SHELF

Inclined shelf with 6 removable dividers  
To combine with the uprights of serie 5003 MF  
Dimensions: L. 1425 x D. 275 x H. 185 mm - Weight: 9 Kg

U50030038



DEPTH: 375 MM

## INCLINED SHELF

Inclined shelf with 2 removable dividers  
To combine with the uprights of serie 5003 ME  
Dimensions: L. 435 x D. 375 x H. 185 mm - Weight: 3,5 Kg

U50030041



## INCLINED SHELF

Inclined shelf with 4 removable dividers  
To combine with the uprights of serie 5003 ME  
Dimensions: L. 682,5 x D. 375 x H. 185 mm - Weight: 5 Kg

U50030044



## INCLINED SHELF

Inclined shelf with 4 removable dividers  
To combine with the uprights of serie 5003 ME  
Dimensions: L. 930 x D. 375 x H. 185 mm - Weight: 7,5 Kg

F50030042



## INCLINED SHELF

Inclined shelf with 6 removable dividers  
To combine with the uprights of serie 5003 ME  
Dimensions: L. 1425 x D. 375 x H. 185 mm - Weight: 10 Kg

F50030043

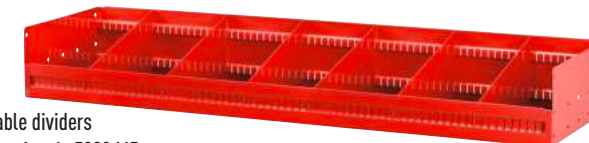

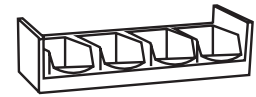

## TRAY-HOLDERS - SERIE 5003 A1

Supplied with plastic trays 5003/1A  
To combine with the uprights  
of serie 5003 MD



<b>U50030067</b>	Dimensions: L. 682,5 x D. 200 x H. 90 mm - Weight: 2,9 Kg
<b>U50030068</b>	Dimensions: L. 930 x D. 200 x H. 90 mm - Weight: 3,5 Kg
<b>U50030069</b>	Dimensions: L. 1177,5 x D. 200 x H. 90 mm - Weight: 5 Kg
<b>U50030070</b>	Dimensions: L. 1425 x D. 200 x H. 90 mm - Weight: 7,5 Kg

## TRAY-HOLDERS - SERIE 5003 A2

Supplied with plastic trays 5003/1B  
To combine with the uprights of serie 5003 MF



<b>F50030072</b>	Dimensions: L. 682,5 x D. 275 x H. 140 mm - Weight: 6 Kg
<b>F50030073</b>	Dimensions: L. 930 x D. 275 x H. 140 mm - Weight: 7 Kg
<b>F50030074</b>	Dimensions: L. 1177,5 x D. 275 x H. 140 mm - Weight: 9 Kg
<b>F50030075</b>	Dimensions: L. 1425 x D. 275 x H. 140 mm - Weight: 10 Kg

## TRAY-HOLDERS - SERIE 5003 A3

Supplied with plastic trays 5003/1C  
To combine with the uprights of serie 5003 ME



<b>F50030077</b>	Dimensions: L. 682,5 x D. 375 x H. 175 mm - Weight: 6 Kg
<b>F50030078</b>	Dimensions: L. 930 x D. 375 x H. 175 mm - Weight: 7 Kg
<b>F50030079</b>	Dimensions: L. 1177,5 x D. 375 x H. 175 mm - Weight: 9 Kg
<b>F50030080</b>	Dimensions: L. 1425 x D. 375 x H. 175 mm - Weight: 10 Kg

## PLASTIC TRAY - 5003/1A

Plastic tray for 5003 A1  
Dimensions: L. 115 x D. 165 x H. 75 mm  
Weight: 86 gr



**F50030001Q**

## PLASTIC TRAY - 5003/1B

Plastic tray for 5003 A2  
Dimensions: L. 160 x D. 230 x H. 125 mm  
Weight: 180 gr



**F50030002Q**

## PLASTIC TRAY - 5003/1C

Plastic tray for 5003 A3  
Dimensions: L. 220 x D. 340 x H. 165 mm  
Weight: 412 gr



**F50030003Q**



## UPRIGHTS 200 MM – SERIE 5003 MD

Two uprights for shelves depth 200 mm  
Can be put on vehicle floor or on chests

- U50030046** Dimensions: L. 30 x D. 200 x H. 222 mm - Weight: 1,5 Kg
- U50030047** Dimensions: L. 30 x D. 200 x H. 382 mm - Weight: 2,5 Kg
- U50030048** Dimensions: L. 30 x D. 200 x H. 542 mm - Weight: 3,4 Kg

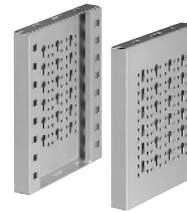

## UPRIGHTS 275 MM – SERIE 5003 MF

Two uprights for shelves depth 275 mm  
Can be put on vehicle floor or on chests

- F50030052** Dimensions: L. 30 x D. 275 x H. 222 mm - Weight: 2,1 Kg
- F50030053** Dimensions: L. 30 x D. 275 x H. 382 mm - Weight: 3,6 Kg
- F50030054** Dimensions: L. 30 x D. 275 x H. 542 mm - Weight: 4,8 Kg

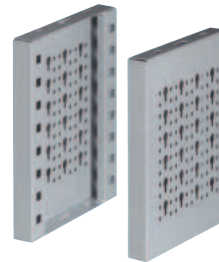

## UPRIGHTS 375 MM – SERIE 5003 ME

Two uprights for shelves depth 375 mm  
Can be put on vehicle floor or on chests

- F50030049** Dimensions: L. 30 x D. 375 x H. 222 mm - Weight: 2,4 Kg
- F50030050** Dimensions: L. 30 x D. 375 x H. 382 mm - Weight: 3,8 Kg
- F50030051** Dimensions: L. 30 x D. 375 x H. 542 mm - Weight: 5,2 Kg

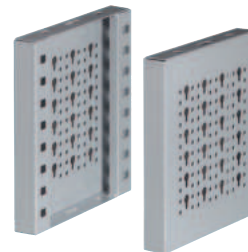

## BASE FOR UPRIGHTS

For more rigidity  
when mounting shelving  
on the floor



- U50030101** Dimensions: L. 435 x D. 30 x H. 90 mm - Weight: 0,8 Kg
- U50030102** Dimensions: L. 682,5 x D. 30 x H. 90 mm - Weight: 1,1 Kg
- U50030103** Dimensions: L. 930 x D. 30 x H. 90 mm - Weight: 1,6 Kg
- U50030104** Dimensions: L. 1177,5 x D. 30 x H. 90 mm - Weight: 2,0 Kg
- U50030105** Dimensions: L. 1425 x D. 30 x H. 90 mm - Weight: 2,4 Kg



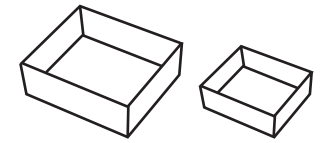

## PLASTIC TRAY

Plastic tray for tool box F50000301  
 Dimensions: L. 74 x D. 64 x H. 51 mm  
 Weight: 22 gr

U50030010Q



## PLASTIC TRAY

Plastic tray for tool box F50000301  
 Dimensions: L. 74 x D. 128 x H. 51 mm  
 Weight: 38 gr

U50030011Q



## PLASTIC TRAY

Plastic tray for tool box F50000301  
 Dimensions: L. 148 x D. 128 x H. 51 mm  
 Weight: 70 gr

U50030012Q



## MODULAR PLASTIC TRAY

Plastic tray for tool box F50000301  
 Dimensions: L. 256 x D. 128 x H. 51 mm  
 Weight: 118 gr

U50030013Q



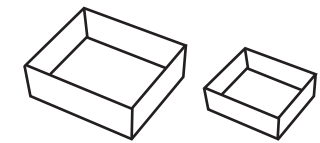

## PLASTIC TRAYS WITH 8 COMPARTMENTS

Model with 8 compartments  
Not recommended for high and long drawers.

Dimensions: L. 400 x D. 315 x H. 50 mm  
Weight: 260 gr

**U50030026Q**



For tool box F50000301  
Dimensions: L. 380 x D. 295 x H. 50 mm  
Weight: 200 gr

**U50030025Q**

## PLASTIC TRAYS WITH 18 COMPARTMENTS

Model with 18 compartments  
Not recommended for high and long drawers.

Dimensions: L. 400 x D. 315 x H. 50 mm  
Weight: 260 gr

**U50030038Q**



For tool box F50000301  
Dimensions: L. 380 x D. 295 x H. 50 mm  
Weight: 200 gr

**U50030037Q**

## PLASTIC TRAYS WITH 12 COMPARTMENTS

Model with 12 compartments  
Not recommended for high and long drawers.

Dimensions: L. 400 x D. 315 x H. 50 mm  
Weight: 260 gr

**U50030030Q**



For tool box F50000301  
Dimensions: L. 380 x D. 295 x H. 50 mm  
Weight: 200 gr

**U50030029Q**

## PLASTIC TRAYS WITH 20 COMPARTMENTS

Model with 20 compartments  
Not recommended for high and long drawers.

Dimensions: L. 400 x D. 315 x H. 50 mm  
Weight: 260 gr

**U50030042Q**



For tool box F50000301  
Dimensions: L. 380 x D. 295 x H. 50 mm  
Weight: 200 gr

**U50030041Q**

## PLASTIC TRAYS WITH 13 COMPARTMENTS

Model with 13 compartments  
Not recommended for high and long drawers.

Dimensions: L. 400 x D. 315 x H. 50 mm  
Weight: 260 gr

**U50030032Q**



For tool box F50000301  
Dimensions: L. 380 x D. 295 x H. 50 mm  
Weight: 200 gr

**U50030031Q**



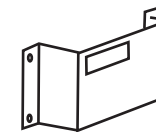

## DIVIDERS (ONLY FOR DRAWERS)

Suitable for drawer chests  
Zinc plated sheet steel dividers (3 pcs.)

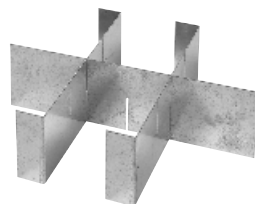

**For drawers H: 75 mm**

**U50030080Q** Dimensions: L. 400 x D. 317 x H. 60 mm - Weight: 0,8 Kg

**For drawers H: 155 mm**

**U50030081Q** Dimensions: L. 400 x D. 317 x H. 120 mm - Weight: 1,6 Kg

## DIVIDERS (ONLY FOR DRAWERS) (2 PCS.)

For drawer chests  
Galvanized sheet steel

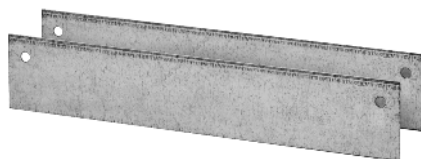

**For drawers H: 75 mm**

**U50030082Q** Dimensions: L. 330 x H. 60 x Th. 2 mm - Weight: 0,5 Kg

**For drawers H: 155 mm**

**U50030083Q** Dimensions: L. 330 x H. 140 x Th. 2 mm - Weight: 1,0 Kg

## CAN FOR WATER WITH HOLDER

Capacity 10 liters with integrated tap  
Stopper of screwed shut  
Dimensions: L. 370 x D. 155 x H. 380 mm  
Weight: 3 Kg (without water)



**U50020131**

## FIRST AID PLASTIC BOX WITH HOLDER

Contents: Sterile gloves (2 pcs.) - 1 Confection of cotton wool  
1 Flacon of cutaneous solution of iodine povi-iodone at 10% of iodine: 125 ml  
1 Flacon of physiological solution (sodium chloride 0,9%) : 250 ml  
1 Compressed of sterile bandage 18 x 40 in single envelopes  
3 Compressed of sterile bandage 10 x 10 in single envelopes  
1 Sterile tweezers for medication - 1 Coil of bandage: 10cm  
Confection of plasters of several measures ready to use (1 Pc)  
1 Scissors - 1 Emostatic lace - 1 Confection of instant ice  
1 Bags for the collection of sanitary wastes - 1 Coil of plaster: 2,5cm  
Instructions on the way to use the aforesaid headmasters  
and lend the first aids waiting for emergency service.  
Dimensions: L. 375 x D. 105 x H. 215 mm  
Weight: 2,3 Kg

**U50020132**

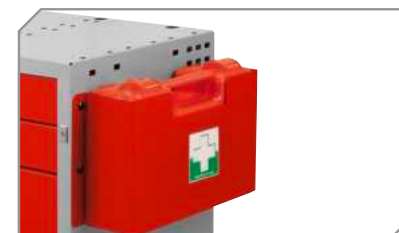

## VICE HOLDER

Sheet steel tubular casing  
Max opening: 1080 mm  
Dimensions: L. 70 x D. 110 x H. 710 mm  
Weight: 4 Kg

**U50020082**

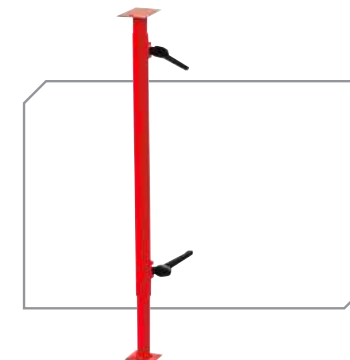

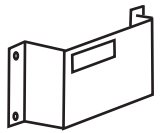

## REMOVABLE TOOL BOX

Tool box arranged to fit the plastic trays  
(page 17 and 18)  
Clip lock and handle for transport  
Maximum load 5 Kg  
Dimensions: L. 403 x D. 312 x H. 62 mm  
Weight: 2,3 Kg

F50000301



## REMOVABLE TOOL BOX

Tool box with clip lock and handle  
for transport  
Maximum load 12 Kg  
Dimensions: L. 403 x D. 312 x H. 135 mm  
Weight: 3 Kg

F50000302



## BOTTLE HOLDER

Bottle-holder (2 pcs.)  
Sheet steel casing  
Nylon belt with ratchet device  
Weight: 2 Kg

U50020045



## CABLE HOLDER

Completely in plastic material  
Dimensions: L. 260 x D. 160 x H. 150 mm  
Weight: 250 gr

U50020046



## DOCUMENT HOLDER

Dimensions: L. 360 x D. 50 x H. 262 mm  
Weight: 0,8 Kg

U50020064



## SPRAY HOLDER

Dimensions: L. 360 x D. 70 x H. 135 mm  
Weight: 0,6 Kg

U50020067

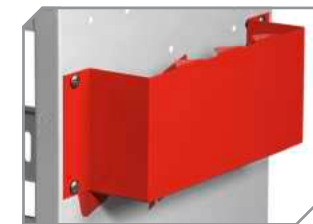

## ROLL HOLDER WITH PAPER CUTTER

Dimensions: L. 360 x D. 50 x H. 265 mm  
Weight: 1,1 Kg

U50020066



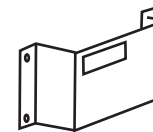

## FIXING BAR SET

Ensures strong and stable fixing of the modules  
Allows to fix the modules easily and quickly  
Suitable for all models of van

### Contents:

Square tubular section bar made of galvanized steel, thickness 1mm (1pz)  
Galvanized steel U-brackets 1mm thick (9 pcs.)  
Plastic spacers (9 pcs.)  
Screws TSPEI M6x60 (4 pcs.)  
Screws TSPEI M8x60 (5 pcs.)  
Screws TBL M6x12 (8 pcs.)  
Washers  $\varnothing$  8x24 (4 pcs.)  
Washers  $\varnothing$  6x18 (5 pcs.)  
Cage nuts M6 (5 pcs.)  
Threaded inserts M6 (4 pcs.)  
Galvanized steel brackets L 240mm thickness 2,5 mm (5 pcs.)  
Galvanized steel spacers thickness 2,5 mm (3 pcs.)  
Plastic closure plugs (2 pcs.)

**F50020048**

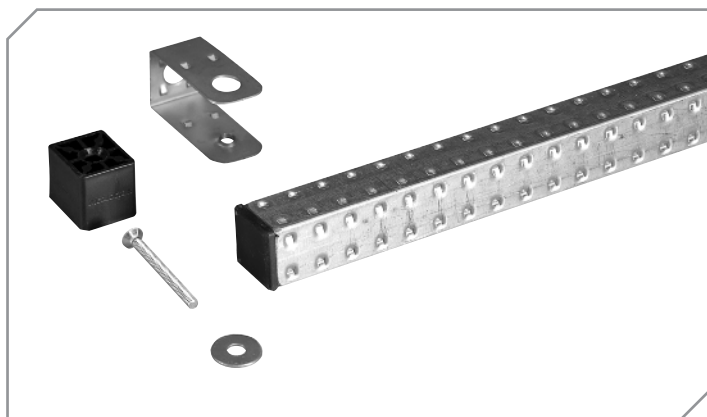

## FIXING BRACKET

Steel thickness 2 mm  
Dimensions: L. 250 x H. 45 mm  
Weight: 146 gr

**U50020047**



## WHEEL SET FOR TOOL CHESTS (2 PCS.)

Included: 2 fixing brackets,  
4 swivelling wheels, 2 of which have a brake  
Rubber wheels  $\varnothing$  80 mm  
Weight: 2 Kg

**U50020061**

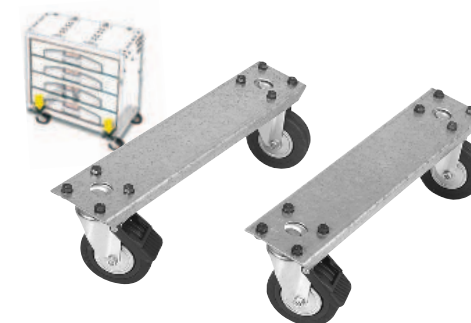

## COVERING TOP

Covering top in zinc-plated sheet steel,  
thickness 2 mm.  
Rear edges to prevent falls.

Dimensions: L. 990 x D. 390 x H. 40 mm

**U50020056**

Dimensions: L. 1485 x D. 390 x H. 40 mm

**U50020057**



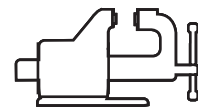

## WORKTOP WITH VICE

Sheet steel structure  
Multilayer wooden plan with vice 1224.100E  
Dimensions: L. 1310 x D. 375 x H. 40 mm  
Weight: 23 Kg

**F50020074**



## WORKTOP WITH VICE

Sheet steel structure  
Sliding multilayer wooden plan with vice 1224.100E  
Dimensions: L. 990 x D. 375 x H. 200 mm  
Weight: 20 Kg

**F50020075**



## WORKTOP WITH VICE

Sheet steel structure  
Multilayer wooden plan with vice 1224.100E  
To be used in combination with base F50020070  
Dimensions: L. 1310 x D. 375 x H. 40 mm  
Weight: 18 Kg

**F50020076**



## FOLDAWAY WORKTOP WITH VICE

Wice-holding sheet steel structure  
Hydraulic pistons to facilitate movements  
Supplied with vice 1224.100E  
Can be fixed to the modules and to the floor panel  
or only to the vehicle floor  
Can also be used with the support for vice U50020082  
Work plan in galvanized metal  
Dimensions (work plan) L. 845 x D. 200 mm  
Dimensions (closed) L. 250 x D. 315 x H. 980 mm  
Dimensions (open) L. 1310 x D. 375 x H. 40 mm - Weight: 22 Kg

**F50020078**



## SPACER FOR VICE HOLDER

To level the module heights on vice sides  
Sheet steel casing  
Dimensions: L. 495 x D. 375 x H. 40 mm  
Weight: 3 Kg

**U50020081**



## SPACER FOR VICE HOLDER

To level the module heights on vice sides  
Sheet steel casing  
Dimensions: L. 247,5 x D. 375 x H. 40 mm  
Weight: 1,5 Kg

**U50020084**





## FOAM TRAYS

Two-colours foam, black with red background  
 Quick check of missing tools  
 Tools blocked during transport  
 No vibration and noise  
 Dimensions suitable for standard drawers  
 Density 33 Kg/m<sup>3</sup>

### MODULE OF WRENCHES

Only for drawers

Dimensions: L. 400 x D. 315 x H. 45 mm

Composition:

- 12 Combination wrenches: 440. 7 - 8 - 9 - 10 - 11 - 12 - 13 - 14 - 17 - 19 - 22 - 24
- 4 Flex head reversible ratchet combination wrenches: 467BF. 8 - 10 - 13 - 17
- 1 Adjustable wrench, Chrome plated 250 mm - 10" - 113A.10C

F50031047

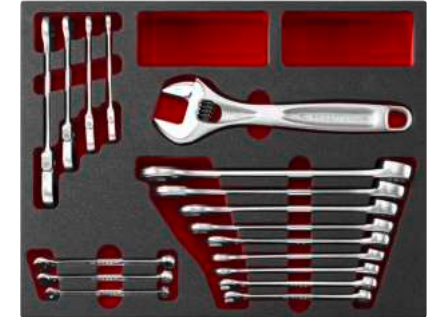

### MODULE OF SCREWDRIVERS AND HEX KEYS

Only for drawers

Dimensions: L. 400 x D. 315 x H. 45 mm

Composition:

- 2 Screwdrivers 1000V insulated for slot-head screws 3,5x100 - 4x100
- 1 Screwdriver 1000V insulated for Phillips® screws PH 2x125
- 5 Screwdrivers for slot-head screws 2,5x50 - 3x75 - 4x100 - 5,5x125 - 6,5x150
- 3 Screwdrivers for Phillips® PH 0x75 - 1x75 - 2x100
- 1 Set of 8 long hexagon keys with spherical head for TORX® screws, long model
- 1 Set of 9 long hexagon keys with spherical head

F50031049



### MODULE OF RATCHETS AND HEXAGONAL SOCKETS 1/4" - 1/2"

Compatible with tool boxes and drawers

Dimensions: L. 380 x D. 295 x H. 45 mm

Composition:

- 17 hexagonal sockets 1/2" 8-10-11-12-13-14-15-16-17-18-19-21-22-24-27-30-32
- 2 extensions 1/2" 125 - 250 mm
- 1 Reversible ratchet 1/2" with sealed mechanism
- 1 T-handle with sliding square drive 1/2"
- 1 Universal joint 1/2"
- 1 assortment with hexagonal sockets and bits in bimaterial box - 1/4" (38 pcs) RL.NANO

F50031051







# *MATRIX*

## THE SOLUTION TO EQUIP EVERY VAN



CONFIGURATOR

